

Product Information

SJ607-R900

Project		Parameter
Degree of the freedom		6
Working radius		905MM
Maximum load		7KG
Rated load		5KG
Working range	J1	-170°/+170°
	J2	-130°/+100°
	J3	-50°/+200°
	J4	-160°/+160°
	J5	-130°/+130°
	J6	-180°/+180°
Position repeatability		±0.05MM
Maximum speed for terminal axis		Casting
Body weight		51KG
Input voltage		220V
Power plant		DC Servo Motor
Reduction gear		Harmonic deceleration
Environmental requirements	Temperature	5°C-50°C
	Humidity	10%-80%
Installation		Table top,side mout,flip mount
Maximum speed	J1	148°/SEC
	J2	148°/SEC
	J3	178°/SEC
	J4	167°/SEC
	J5	178°/SEC
	J6	225°/SEC

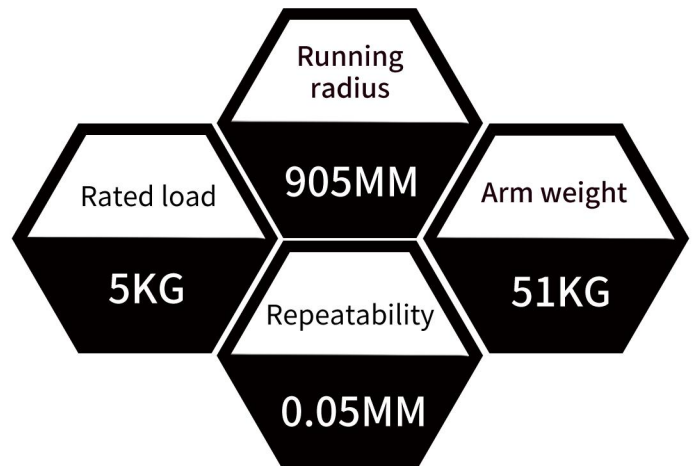

Range Diagram

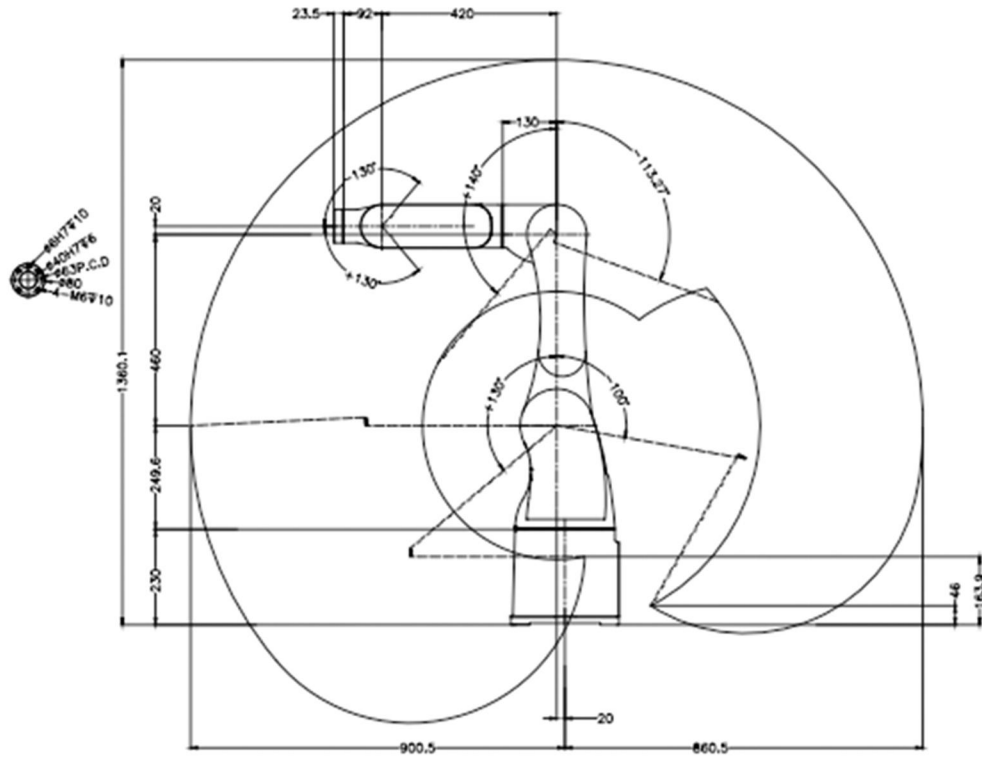

Flange drawing

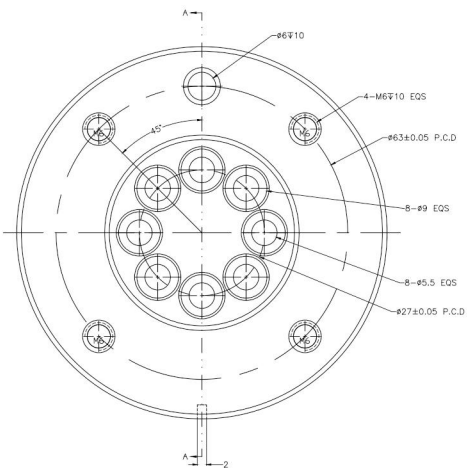

Base installation drawing

